

**BECKHOFF** New Automation Technology

# PC-based Control for the Wood Industry

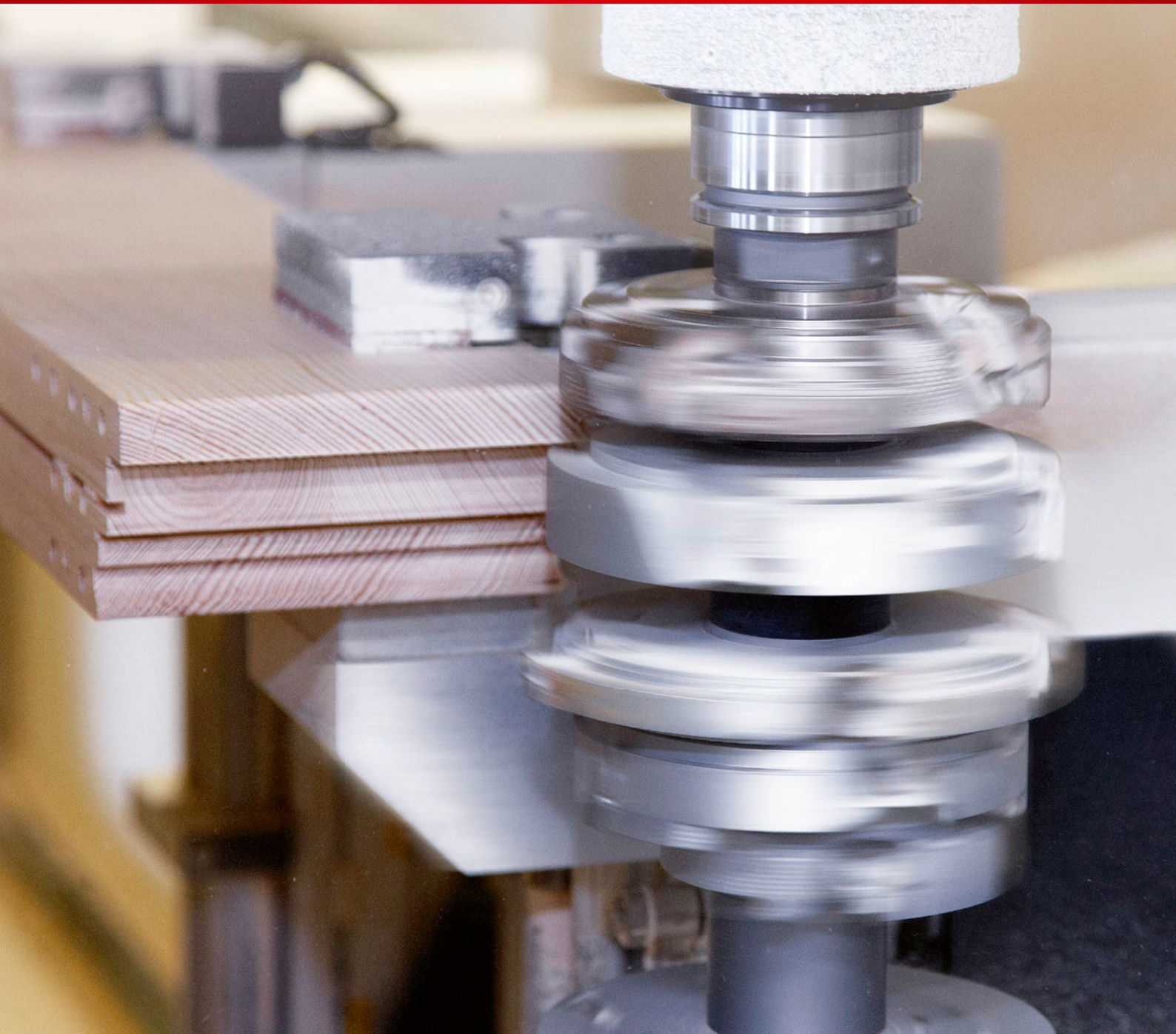

## PC-based control, the open and high-performance control platform ...

PC-based control from Beckhoff provides a control solution for highly efficient and highly flexible woodworking machines. On account of its open interfaces and universality, PC Control helps you realise a wealth of technological and economic competitive advantages. Beckhoff meets the requirements of a global market with local service and support in the required national language through a worldwide sales network of 34\* subsidiaries and representative offices as well as distributors in 75\* countries. Continuous company growth and in-house expertise with a high depth of manufacturing and development ensure the high investment security and long-term availability provided by Beckhoff.

\* as of April 2017



IPC



I/O



Motion



Automation

# ... secures your lead in the furniture industry.

Rapid availability in combination with maximised customisation and high production efficiency represent the main challenges facing the furniture industry and, therefore, the manufacturers of woodworking machines. The open and powerful PC- and EtherCAT-based automation technology from Beckhoff offers an ideal solution. With its high efficiency, modular design and precise scalability in terms of performance the system is optimised for use as a universal hardware and software platform for both individual machine control and end-to-end factory automation. Since all control functions are mapped in software, even unusual requirements can be implemented with little engineering effort, based on standardised processes.

► [www.beckhoff.com/wood](http://www.beckhoff.com/wood)



## All functions integrated on a single platform

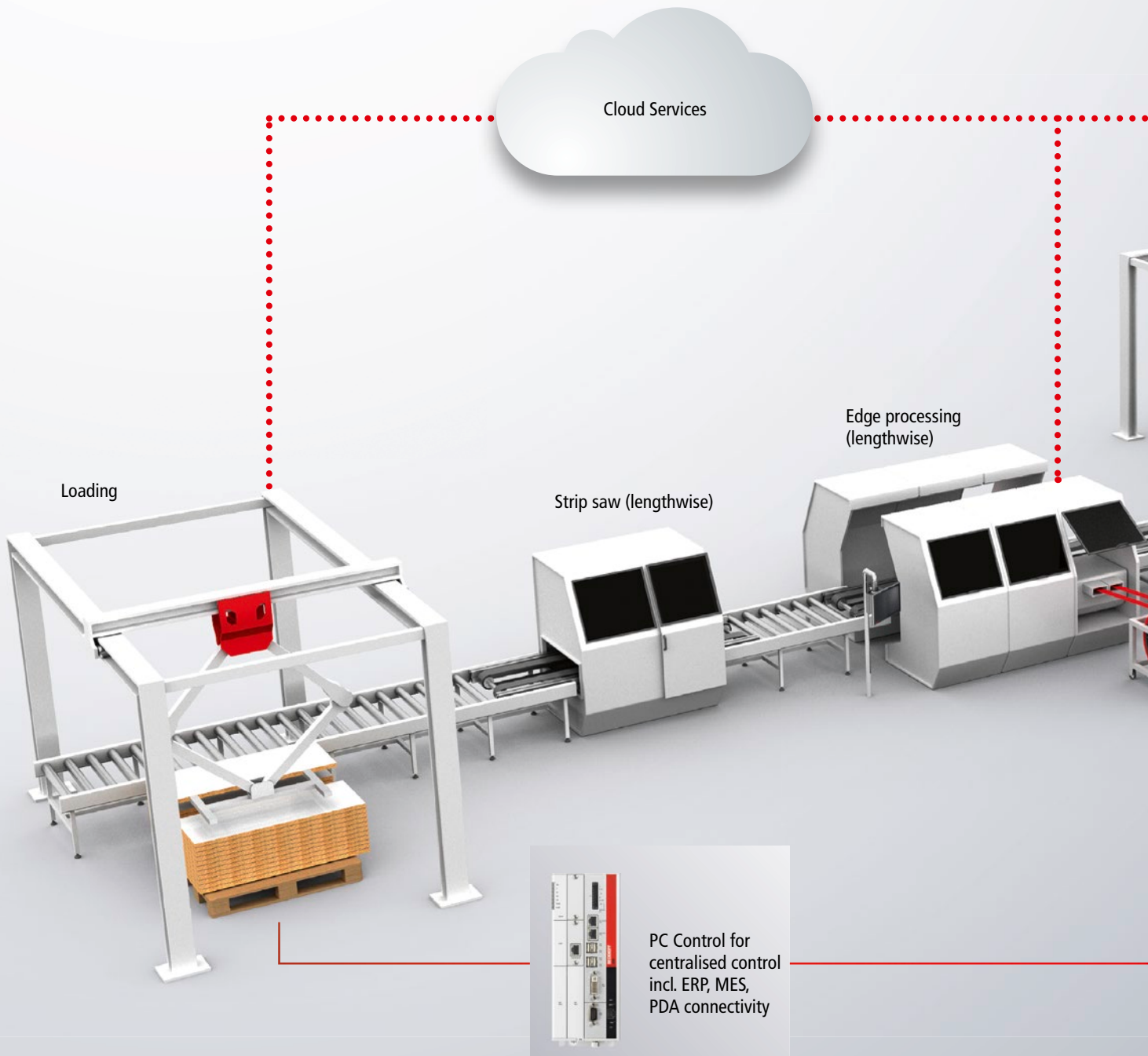

## Networked manufacturing based on the universal PC platform ...

PC Control is based on a uniform hardware and software platform, consisting of Industrial PCs, the EtherCAT communication system as well as decentralised I/Os and drives. TwinCAT is a universal automation software for engineering, execution and diagnosis of all control functions. The open hardware and software interfaces offer high degrees of freedom in machine design, enabling machine manufacturers to integrate a large variety of different devices – including those from third-party vendors. Furniture producers benefit from the openness through increased flexibility to respond to market trends and individual customer requests. Support for all common fieldbus systems and software protocols ensures seamless horizontal and vertical communication: from machine-to-machine communication on the field level to communication with the IT system level and up into the cloud.

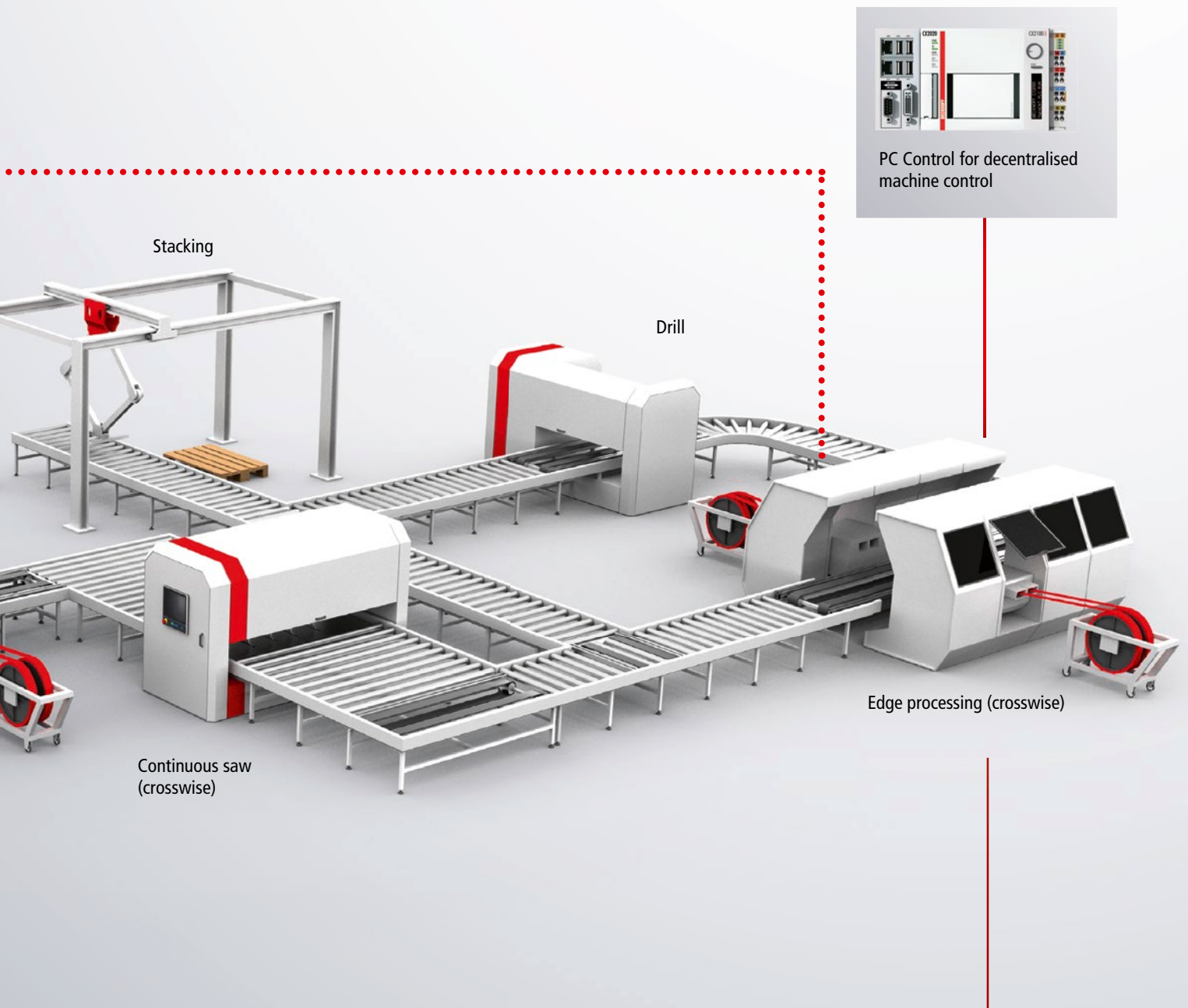

## ... provides for simple and efficient engineering.

The high performance of multi-core and many-core processors means that all machine and plant functions can be implemented with PC-based control. TwinCAT represents a universal tool chain for controlling all conceivable functions: from PLC, Motion Control, CNC and robotics to HMI and vision, and from safety and measurement technology to cloud communication and analytical functions. First, this ensures the efficient interaction of all system components and thus maximised productivity. Second, the consistent implementation of all functionalities as software modules eliminates the need for dedicated devices, reducing not only hardware costs, but above all engineering requirements.



## Profound technology and industry expertise ...

The expertise acquired through decades of collaboration with machine manufacturers and end customers in the woodworking industry makes Beckhoff a reliable partner with exceptionally high solution competence. With PC-based control technology, we provide complete automation solutions for plant and mechanical engineering. Strong industry management and engineering teams offer advice and support for the design, planning, and documentation of your machine through to PLC programming, visualisation, as well as switchgear production, assembly and commissioning – for new systems and for machine retrofits alike.

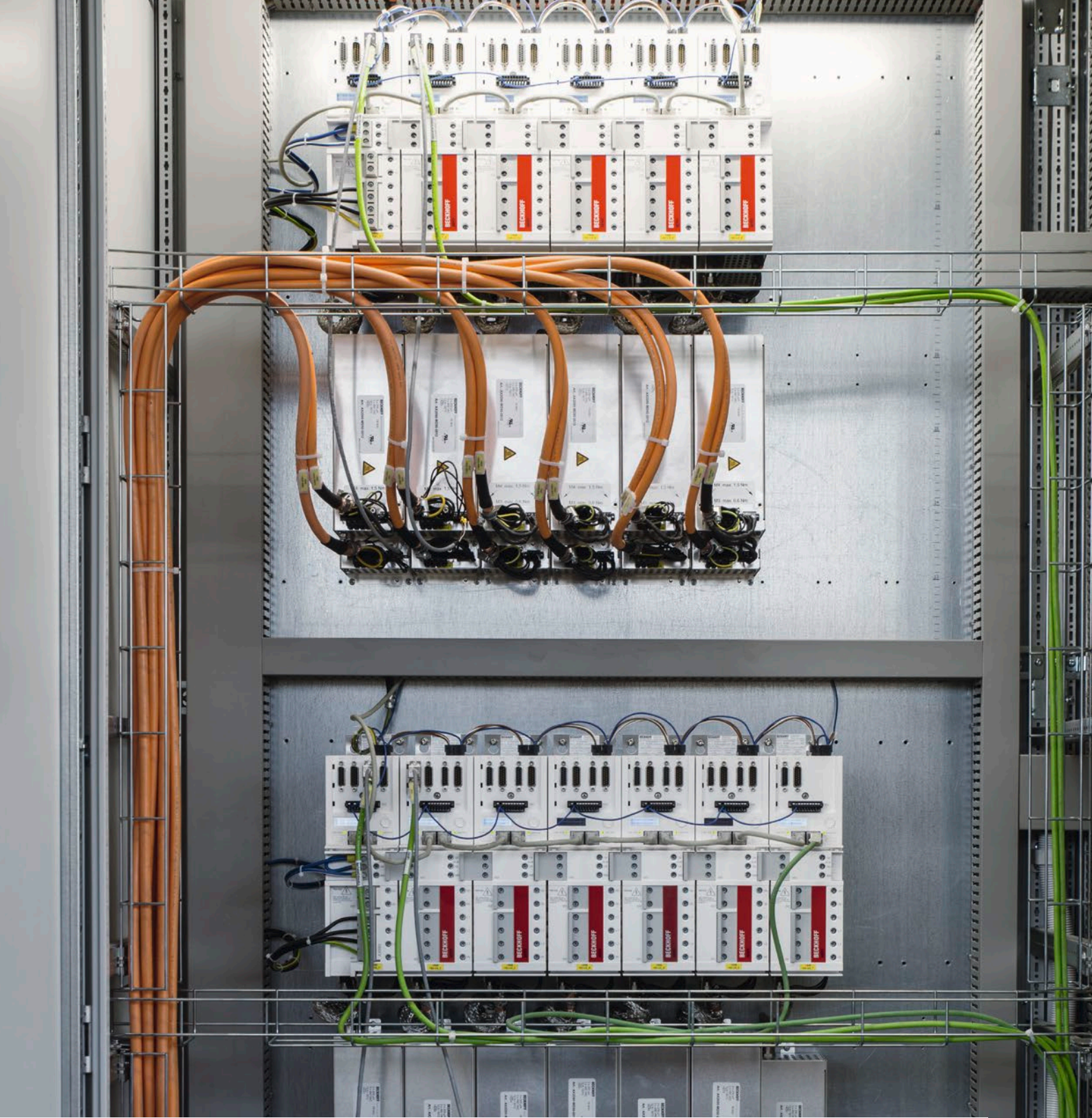

## ... from control cabinet construction to complete production lines.

You as the customer decide whether you engage Beckhoff as a component supplier or as provider of a complete system solution, including such benefits as application support and control cabinet construction. We employ specialists who are available to provide all necessary support for a wide range of machine and plant types, including special applications, supervisory control and MES integration, as well as integration into the enterprise infrastructure. In the Beckhoff Engineering department, the control cabinets can be manufactured exactly to your specifications and standards: from the components used and their location in the control cabinet to EMC-compliant design, suitable air conditioning and ventilation to equipment labelling and logistics.

## Modular and scalable: the Beckhoff automation toolkit



Control Panel: Multitouch display and Control Panel



Industrial PC: Control cabinet and Panel PC



Embedded PC: IPC with integrated I/O level



EtherCAT I/Os: Broad I/O spectrum in IP 20 and IP 67

## The Beckhoff system helps create more efficient woodworking machines ...

Beckhoff offers scalable control solutions in all performance classes and applications in the woodworking and furniture industries: from a compact Embedded PC with integrated I/O connection, up to a high-end IPC with the most powerful multi-core processors. A wide range of multi-touch panels offers advanced functionality and operator comfort at the machine. Over 100 signal types and 1000 different Bus Terminals serve the entire range of sensors and actuators. TwinSAFE provides a universal safety concept that integrates safety functionalities into the standard control platform, including PLC, I/Os and drive technology. The drive technology product portfolio scales from compact servo terminals up to high-performance EtherCAT drives and highly dynamic servomotors with One Cable Technology. At the heart of the solution is TwinCAT software, the engineering and control platform providing open, flexible, and efficient operation for automated systems.



Compact Servo Drives



Servomotors with One Cable Technology



Servo terminals: Compact Drive Technology

TwinCAT: Software for engineering and runtime



TwinSAFE: Integrated safety solution



EtherCAT: Integrated real-time fieldbus for ultra-fast process communication

**EtherCAT** 





# ... highly scalable to suit all types of machine and application scenarios

Beckhoff meets the high requirements of the woodworking and furniture industries with its open, modular software and hardware control solution, which is scalable in terms of computing power, performance, complexity and costs. Selecting from a modular range of components as if from an automation toolkit, users can assemble a control solution to suit their machine type and dimension it according to their performance requirements. If desired, services and applications can also be outsourced to a private or public cloud. The modularity of the PC-based control system and its openness with regard to the wide range of supported fieldbus systems and communication protocols enables step-by-step system conversion as well as the expansion of existing machines and equipment.

# Creating added value: with Industrie 4.0 in woodworking

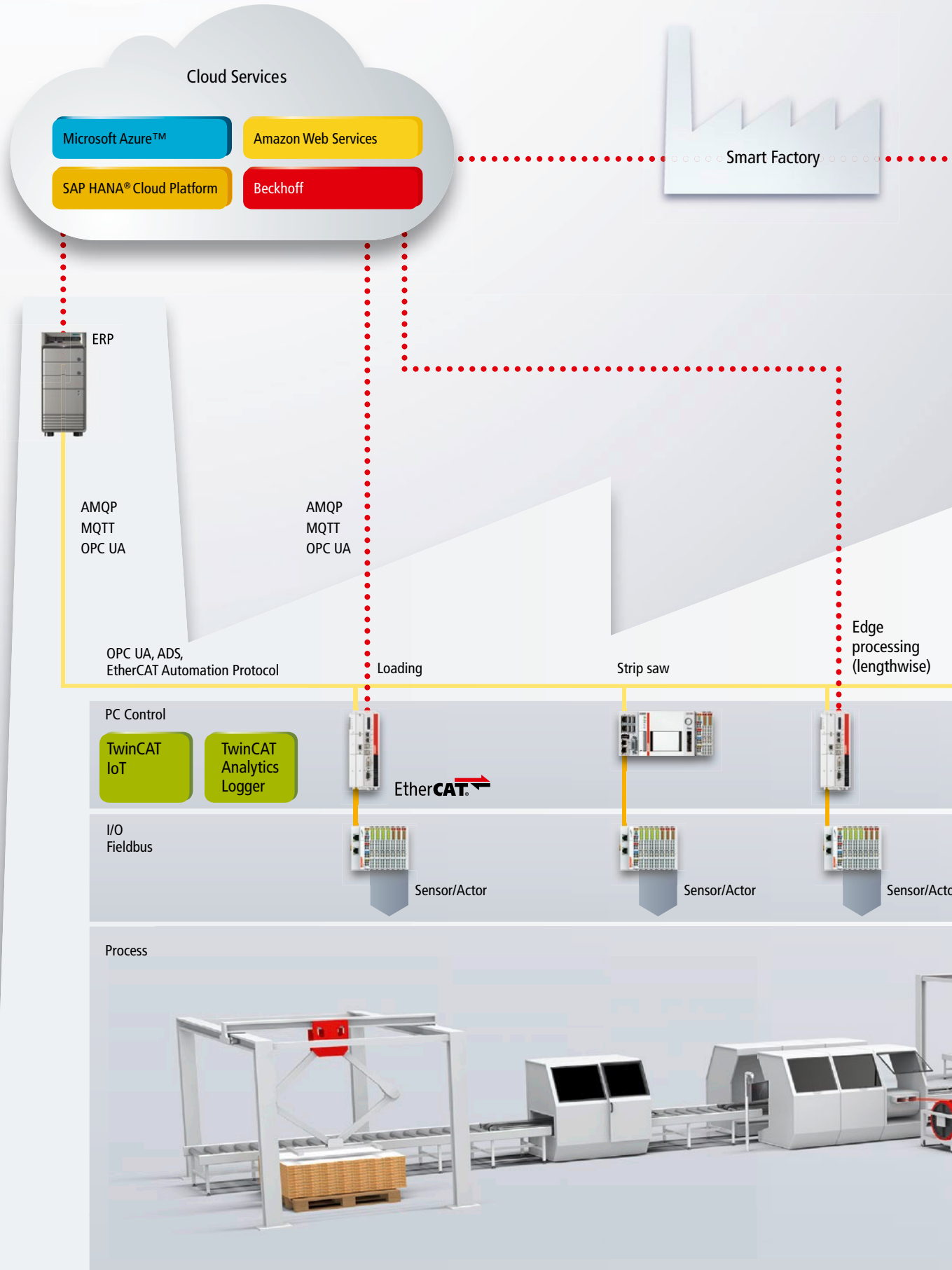



With standardised interfaces for industrial communication and IT, PC-based control offers the ideal foundational technology for realising Industrie 4.0 concepts in furniture production. In the Smart Factory, all systems involved in manufacturing processes are seamlessly connected from the control level to the production planning level so that changes can be implemented in job planning and also in the running production. This enables the economical production of individualised products down to a lot size of 1, but under mass production conditions. Apart from conventional control tasks, TwinCAT can also be used to realise vision applications, e.g. for determining the position and orientation of components, or condition monitoring for predictive maintenance, or power monitoring and management, so that – depending on the implementation – the production efficiency and uptime of machines and systems can be sustainably increased.

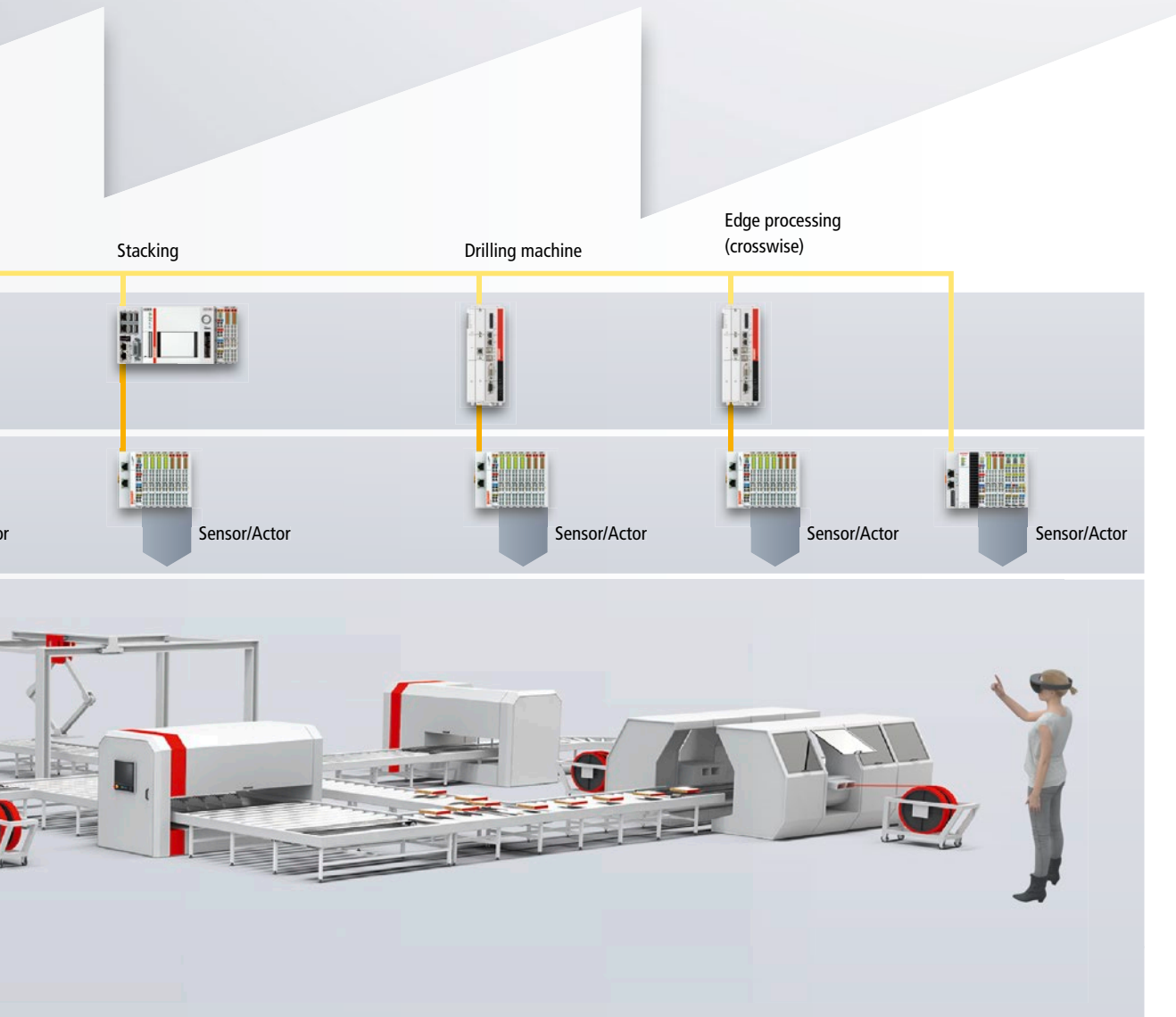

## TwinCAT, the universal solution for woodworking ...

TwinCAT automation software consists of runtime systems for real-time execution of PLC, NC, CNC and robotics applications and provides the ideal engineering environment for programming, diagnostics and configuration. All relevant IEC 61131-3 programming languages are available for real-time applications. C/C++ and MATLAB®/Simulink® modules can be integrated into the IEC context via existing interfaces or else operated independently in the TwinCAT real-time environment. Moreover, open interfaces as well as the use of the latest technological standards based on Windows operating systems open up a wide range of options for the user, such as integration in existing visualisation, higher-level control and database systems.

► [www.beckhoff.com/TwinCAT](http://www.beckhoff.com/TwinCAT)



### TwinCAT high-end PLC

- high degrees of freedom in programming: IEC 61131, C/C++, MATLAB®/Simulink®
- reusable software modules
- almost unlimited memory
- any number of function blocks and variables possible
- shortest PLC cycle times through native code generation
- high-speed software solutions for cam controllers, governors, etc.
- wide range of software libraries

### TwinCAT Motion Control

- point-to-point motion
- gear coupling
- master/slave couplings: cam plate, linear path control
- synchronous position coupling (flying saw)
- superposition
- print mark detection (touch probe)
- phasing
- multi-master coupling
- axis interpolation in 3 dimensions
- 64 axes in up to 12 channels
- interpolation of up to 32 axes per channel
- real-time transformations, RTCP

## ... as a universal engineering and control platform

TwinCAT is a tool chain that is optimised for mechanical engineering, simplifying the implementation of all control applications, HMI, IoT communication and analytical functions can be implemented. Multi-core and many-core technologies are fully supported by TwinCAT so that the above functions can be implemented in the best-possible way. The object-oriented extensions of IEC 61131-3 enable the modularisation of programming code, the software encapsulation of machine functions and, in conjunction with that, improved structuring, simpler maintenance, re-usability and expandability of the software. Extensive software function blocks and libraries for industry-specific applications facilitate the engineering and implementation of specific machine functions. The TwinCAT Automation Interface supports the user with automatic code generation for machine configuration.



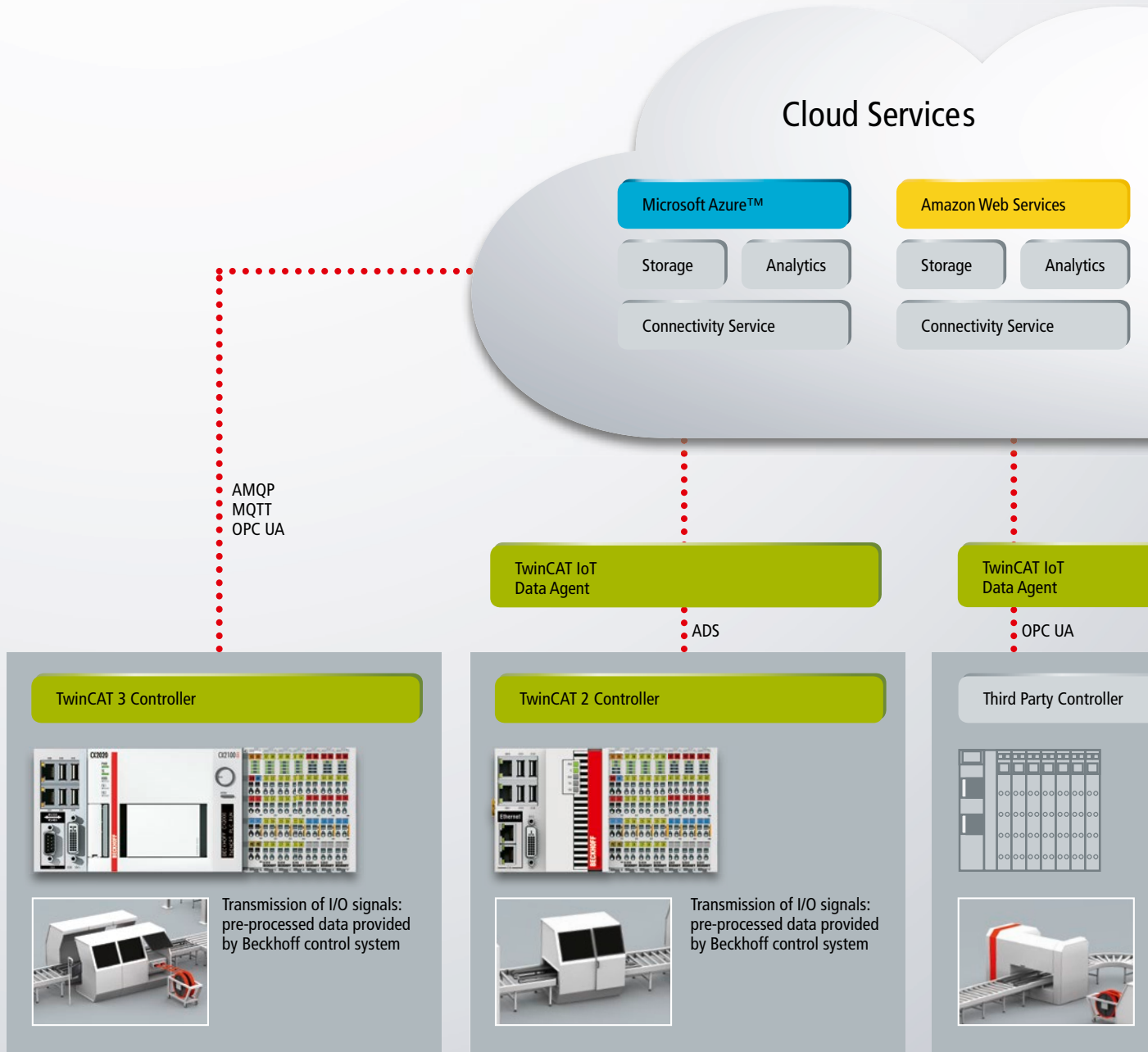

## TwinCAT IoT for cloud communication

Beckhoff has developed the TwinCAT IoT software library to simplify the communication between machine controllers and cloud-based services. It offers support for standardised protocols such as OPC UA, AMQP and MQTT to enable communication with common cloud systems, such as Microsoft Azure™, Amazon Web Services and SAP HANA, as well as private cloud systems in company networks. Built-in security mechanisms prevent unauthorised access and misuse of confidential data in order to protect a company's intellectual property.

► [www.beckhoff.com/TwinCAT-Industrie40](http://www.beckhoff.com/TwinCAT-Industrie40)

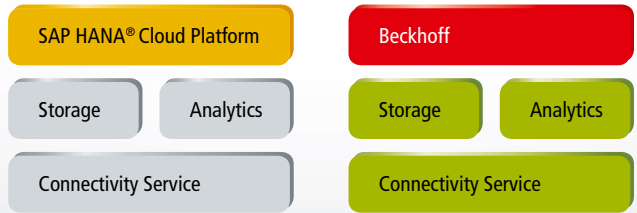

Transmission of I/O signals:  
pre-processed data provided  
by third-party control system

### IoT Bus Coupler



Transmission of any I/O  
signals without the need  
to use PLC

### TwinCAT Analytics



Applications for maintenance and analytics



## TwinCAT Analytics for data analysis

By means of TwinCAT Analytics, process data are recorded and analysed synchronously with the machine cycle and can be used, among other things, as a basis for predictive maintenance and machine optimisation. Using appropriate analysis tools, all required information can be derived from the acquired data in order to optimise a machine e.g. with regard to energy efficiency or the process sequence. Post-mortem analysis, diagnosis of sporadic errors or early detection of quality losses as well as production bottlenecks, will increase the reliability and uptime of production lines. Data analysis also provides machine builders with extensive information about the performance of their machines, which can be leveraged in future design and manufacturing processes in order to reduce costs and optimise machine specifications.



With TwinCAT HMI and the extensive product range of Control Panels and Panel PCs, Beckhoff offers a scalable hardware and software range for flexible operating concepts.

- Simple, open, HTML5-based
- Platform-independent
- Visual Studio® integration
- Parameterisation instead of programming



## The faster way to individualised operating interfaces

TwinCAT HMI makes consistent use of established IT standards such as HTML5, Java Script and CSS. The integration of a fully graphical editor with an extensive toolbox into the familiar TwinCAT engineering environment simplifies the creation of comprehensive visualisation pages. Customer-specific functions that are not already part of the visualisation toolkit can be easily implemented using the IT standards mentioned above or higher-level programming languages. The visualisations created are platform-independent and "responsive" on the client side. The powerful basic architecture makes numerous application scenarios possible: from localised panel solutions to multi-client, multi-server and multi-runtime concepts.

► [www.beckhoff.com/TwinCAT-HMI](http://www.beckhoff.com/TwinCAT-HMI)



# TwinCAT CNC integrates control system and CNC functionalities

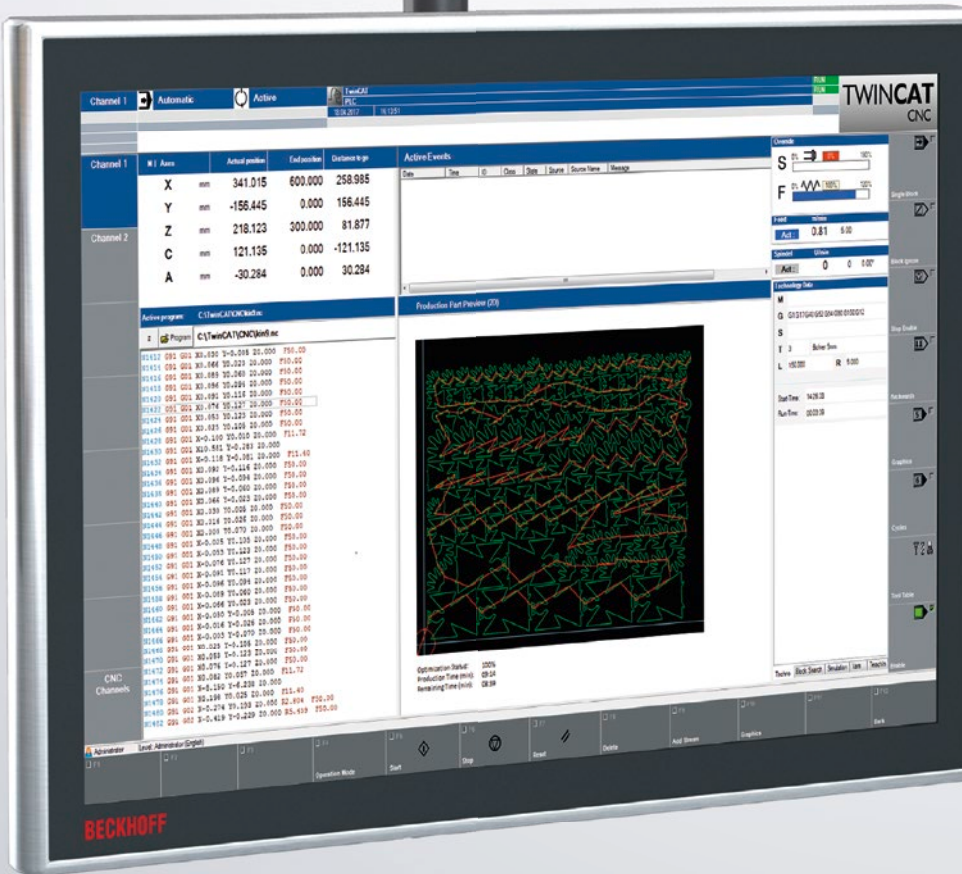

Control Panels for woodworking with innovative multi-touch operating technology

- Display sizes from 7 to 24 inches
- Wide variety with regard to formats, connection technology and processing power
- Maximised flexibility



## High-performance CNC solution for high-end applications

With TwinCAT CNC, Beckhoff offers high-end CNC functionalities as an all-software solution. With the powerful PC platform and the hard real-time basis of the TwinCAT real-time kernel all requirements can be satisfied in an ideal way: TwinCAT CNC covers the entire range from conventional CNC path control through to high-end systems with complex motion control and kinematic requirements. All required axis and spindle functions, interpolation and feed functions, tool and help functions according to DIN 66025 with specific expansions are available for a variety of machining technologies (e.g. milling, drilling, handling, special machines). These functions are supplemented, for example, by volumetric compensation (measurement and compensation of workspaces) and the calibration of complex tools (5-axis heads). Since the CNC solution from Beckhoff is scalable and modular it exactly meets the requirements of modular and multi-functional machine concepts.

► [www.beckhoff.com/CNC](http://www.beckhoff.com/CNC)

## One Cable Automation for the field level

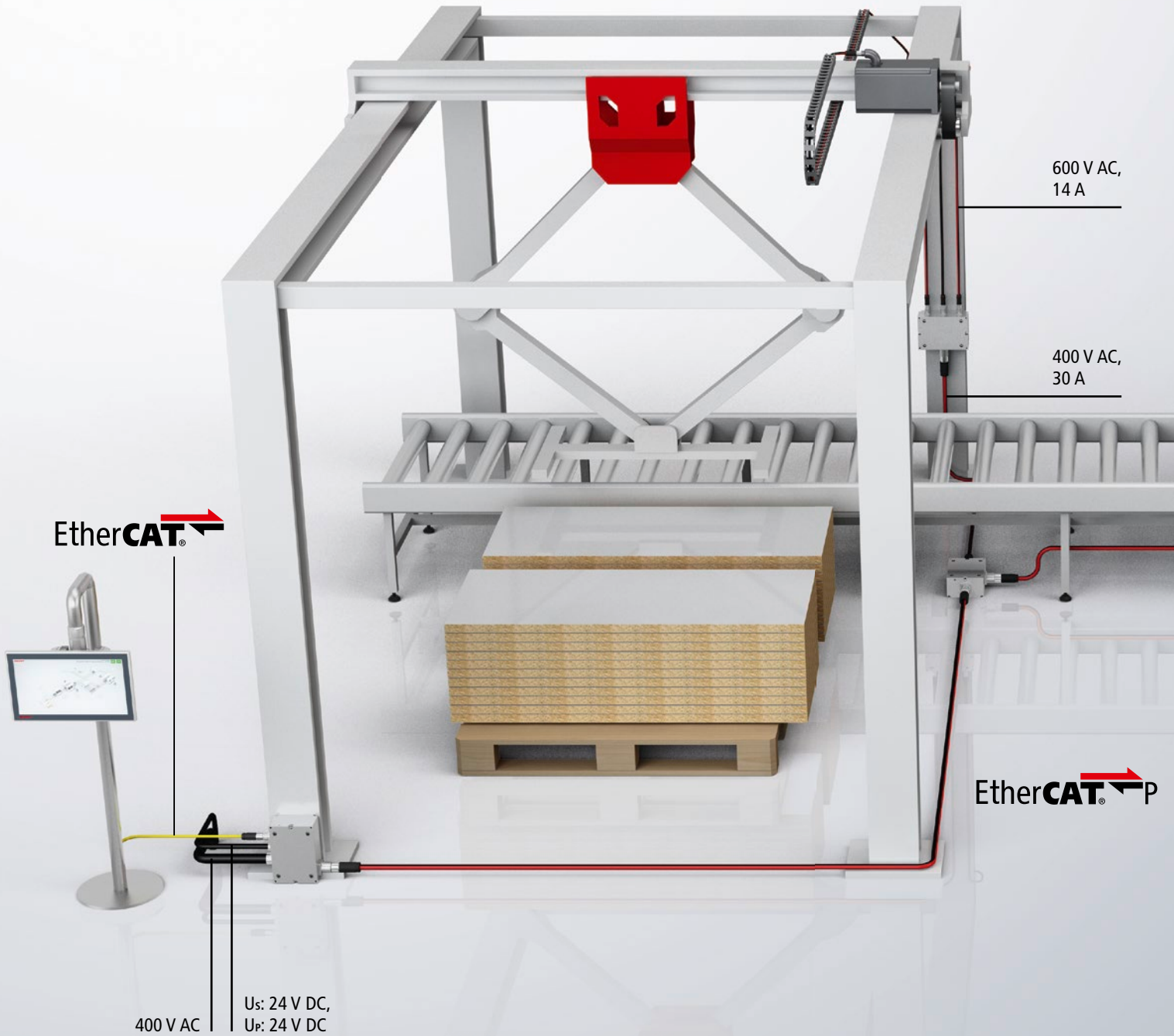

## EtherCAT P, the One Cable Technology ...



EtherCAT P combines EtherCAT communication with power supply for connected devices in a standard 4-wire Ethernet cable. In addition, EtherCAT P enables direct forwarding of power supply via the devices. All benefits of EtherCAT are retained, including free choice of topology, high speed, optimum bandwidth utilisation, telegram processing on the fly, highly precise synchronisation, extensive diagnostics functionality, etc. EtherCAT P is the ideal bus system for sensors, actuators and measurement technology. One Cable automation simplifies system wiring in machine building, since components, terminal boxes and machine modules only have to be connected via a single cable.

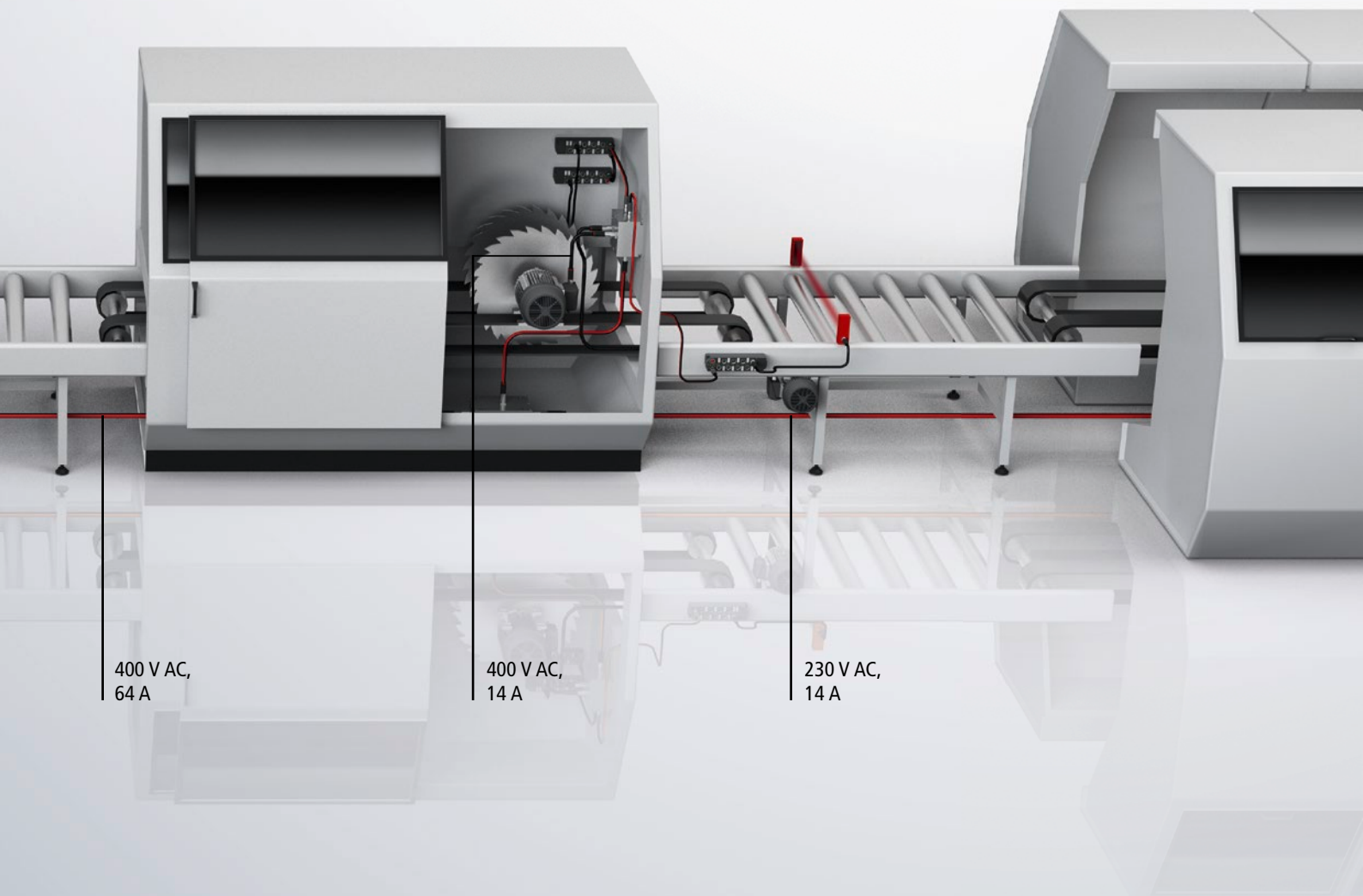

## ... minimises cabling and assembly costs.

With One Cable Automation, decentralised modules and units are supplied with control data and power via just one cable. Conventional switchboxes and control cabinets can thus be reduced in size or even entirely dispensed with, reducing the system footprint and complexity at the same time. EtherCAT P makes it possible to implement modular machines and system concepts with high flexibility and considerably reduced installation and commissioning effort. Hardware costs, installation costs and time are reduced, as is the risk of errors during installation.

► [www.beckhoff.com/EtherCAT-P](http://www.beckhoff.com/EtherCAT-P)

Safety-related drive functions, such as STO, SDI, SOS, SLS and SLP

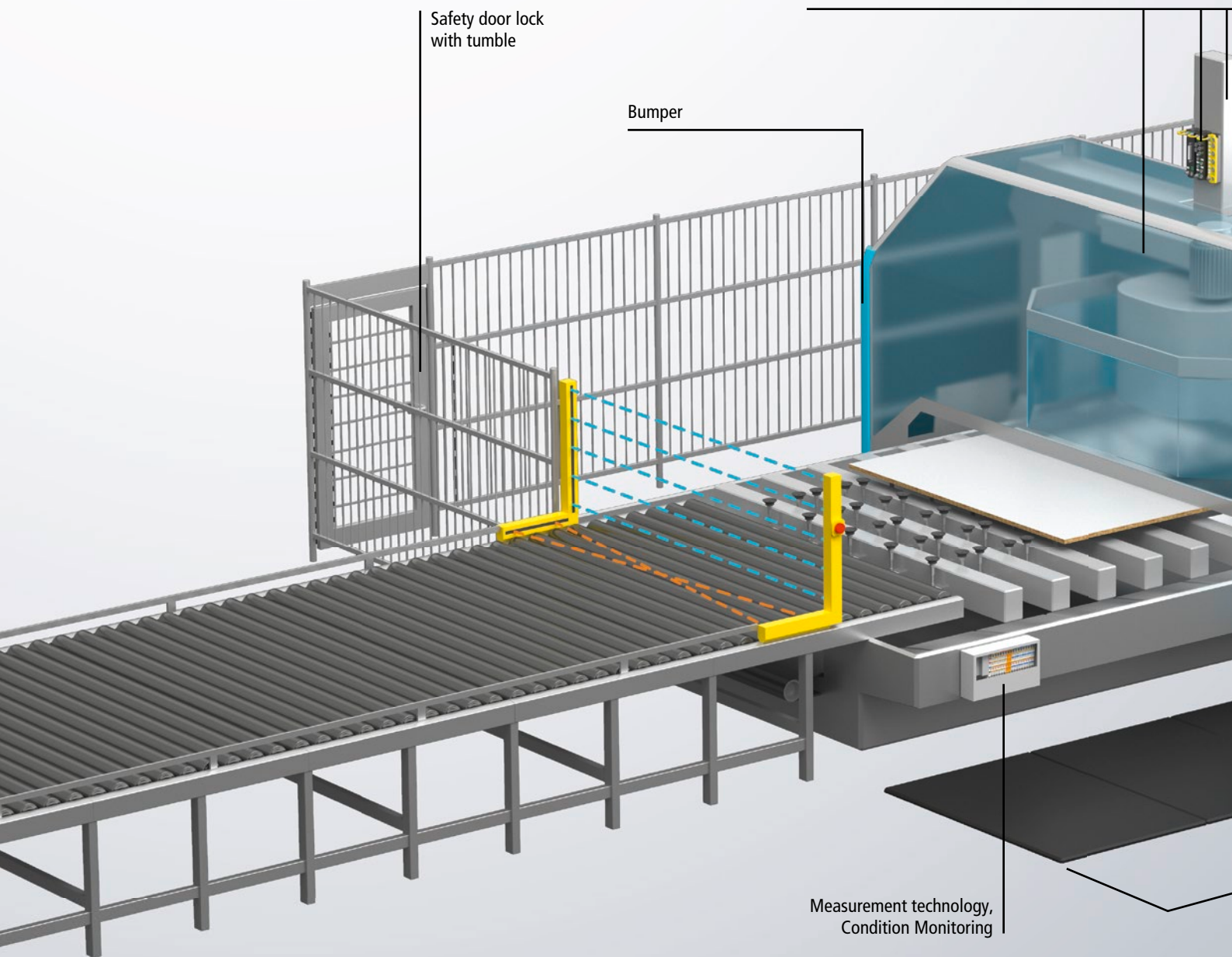

## TwinSAFE, the scalable safety solution in software and hardware ...

TwinSAFE from Beckhoff provides a universal safety concept that integrates safety-related functionalities into the standard control platform: from PLC and I/Os to drive technology. All safety functions such as e.g. emergency stop, safety door monitoring, two-hand operation, safety mat evaluation and muting, safe position, safely limited speed, and more, can be programmed and configured on the integrated TwinCAT engineering platform. Safety technology is seamlessly integrated with the I/O terminal system via the TwinSAFE I/O modules, whereby safe signals can be mixed with standard signals as required. With the help of TwinSAFE SC technology it is possible to make use of standard signals for safety applications in any network or fieldbus systems. For this purpose, specific EtherCAT Terminals with TwinSAFE SC functionality can be used, which are suitable to acquire these signals and safely transmit them via EtherCAT.

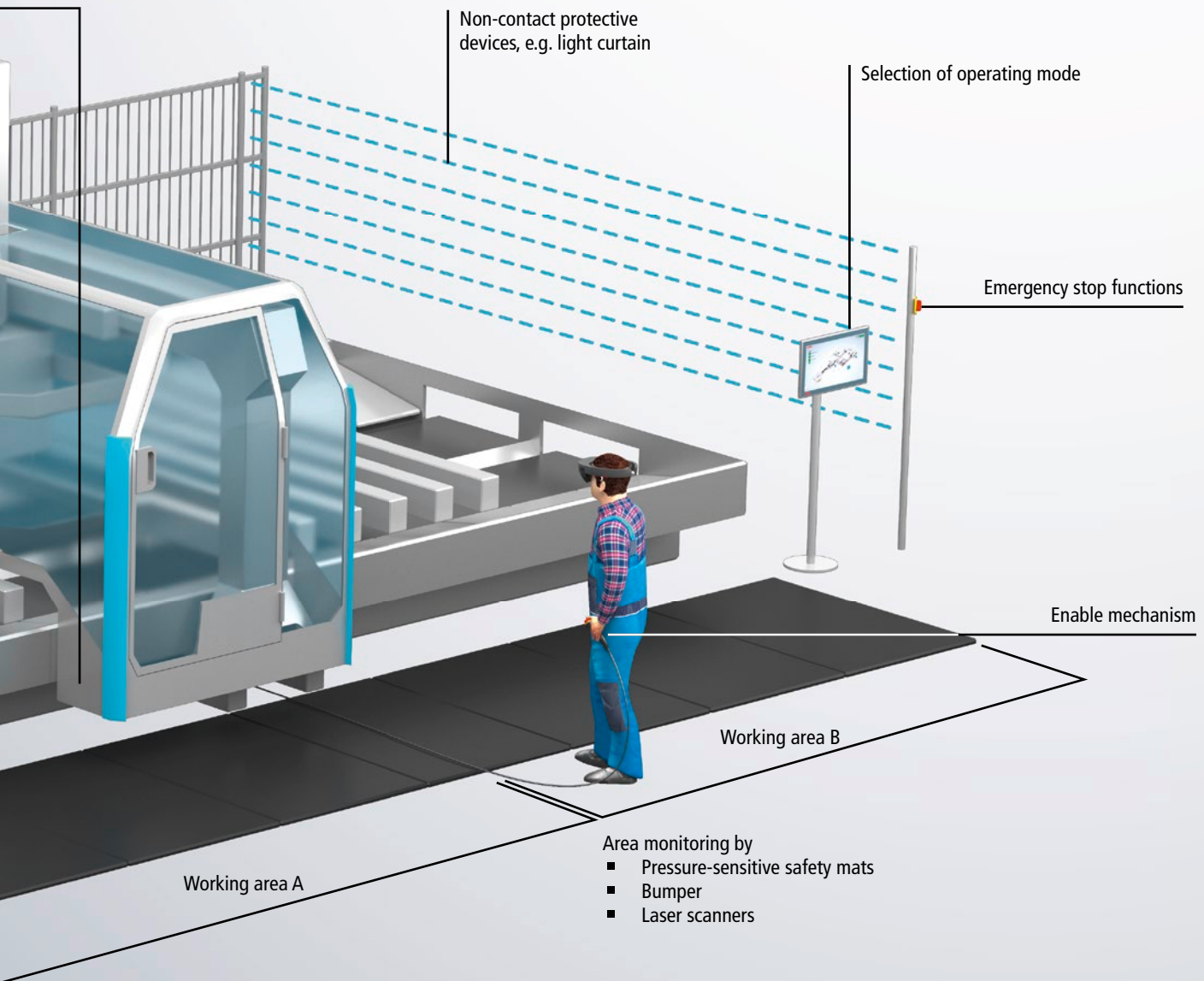

## ... ensures safety for humans and machines.

Typical safety functions can be programmed and configured on the EL6900 and EL6910 TwinSAFE PLCs or the compact EK1960 safety controller, based on standard safety function blocks according to individual safety requirements. All safety controllers are suitable for applications up to SIL 3 according to IEC 61508 and performance level e of ISO 13849-1. The EL6910 and also the EK1960 safety controllers support complex and safe analog evaluations, e.g. for safe limitation of process parameters such as pressure, temperature, and the speed of frequency-controlled drives.

► [www.beckhoff.com/TwinSAFE](http://www.beckhoff.com/TwinSAFE)

Servo Drives from 0.2 to 120 KW  
Servomotors from 0.2 to 180 Nm



## EtherCAT drives for highly dynamic positioning tasks ...

The scalable drive solutions from Beckhoff cover a broad range of applications: from compact servo terminals to AX8000 or AX5000 EtherCAT Servo Drives. The integrated, fast control technology of the AX series supports fast and highly dynamic positioning tasks. EtherCAT offers the ideal link to PC-based control technology, and interfaces to other communication systems. The extensive range of linear and rotary servomotors is optimally matched to the Beckhoff Servo Drives. The AM8000 motor series is characterised by One Cable Technology (OCT), where power and feedback systems are combined in a single standard cable. The servo terminals represent an inexpensive and compact alternative in the lower performance range.

► [www.beckhoff.com/motion](http://www.beckhoff.com/motion)



## ... ensure the highest-possible precision in woodworking.

Woodworking requires a high degree of precision: milling and sawing, gluing, drilling and plugging, as well as various assembly processes must be carried out with great precision in order to produce high-quality furniture. Any deviation has an impact on quality and may necessitate costly reworking or even rejection of bad parts, causing a negative effect on throughput and the logistics chain. In combination with TwinCAT Motion Control software, the Beckhoff drive system covers the high requirements of the wood and furniture industry. Simple positioning drives play an increasingly important part as the degree of automation increases. Beckhoff offers a full range of drives, as well, including stepper motors, DC motors, or compact servomotors.

### Transport, feeding, de-stacking

Scalable hardware and software components support all drive technologies, independent of the manufacturer: from simple roller tracks to powerful portal solutions, and from three-phase asynchronous motors and servomotors to the smallest positioning motors. The integrated TwinSAFE safety solution ensures universal safety up to SIL 3 (IEC 61508) and PLe (EN ISO 13849-1) from the I/Os through to the drive level.

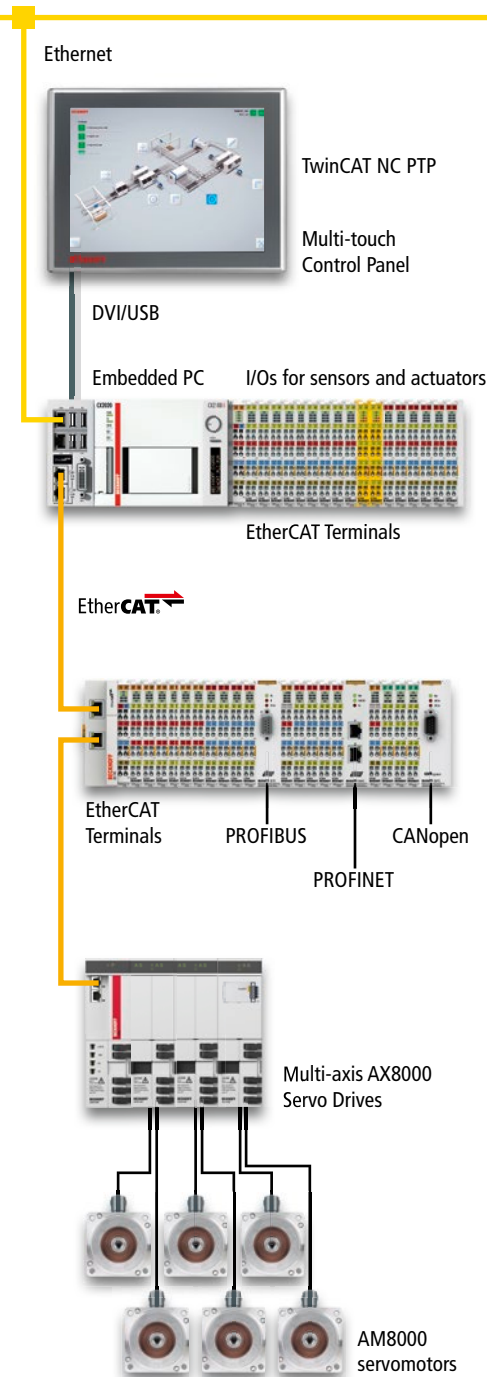

### Edge processing

High-performance Industrial PCs and the fast EtherCAT bus system adequately meet growing requirements for computing power and bandwidth, ensuring integrated communication between the controller and the sensor/actuator level. A heterogeneous infrastructure with different fieldbus systems can all be replaced by EtherCAT. This also applies to the safety technology, which integrates seamlessly with the bus system.

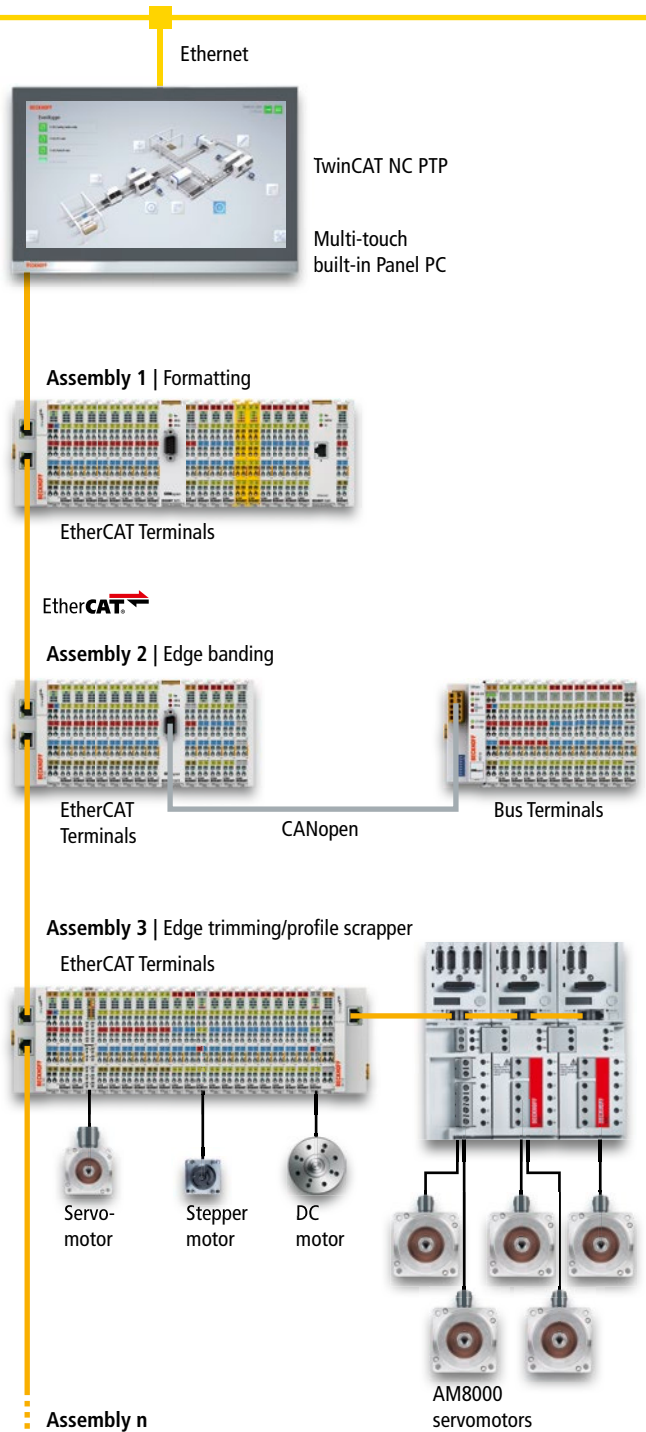



## CNC machining centre

Modern Industrial PCs and TwinCAT automation software from Beckhoff offer sufficient resources to execute PLC and CNC on a single controller. Integrated networking with EtherCAT and optimal integration of servo drive technology simplify the control topology even further.

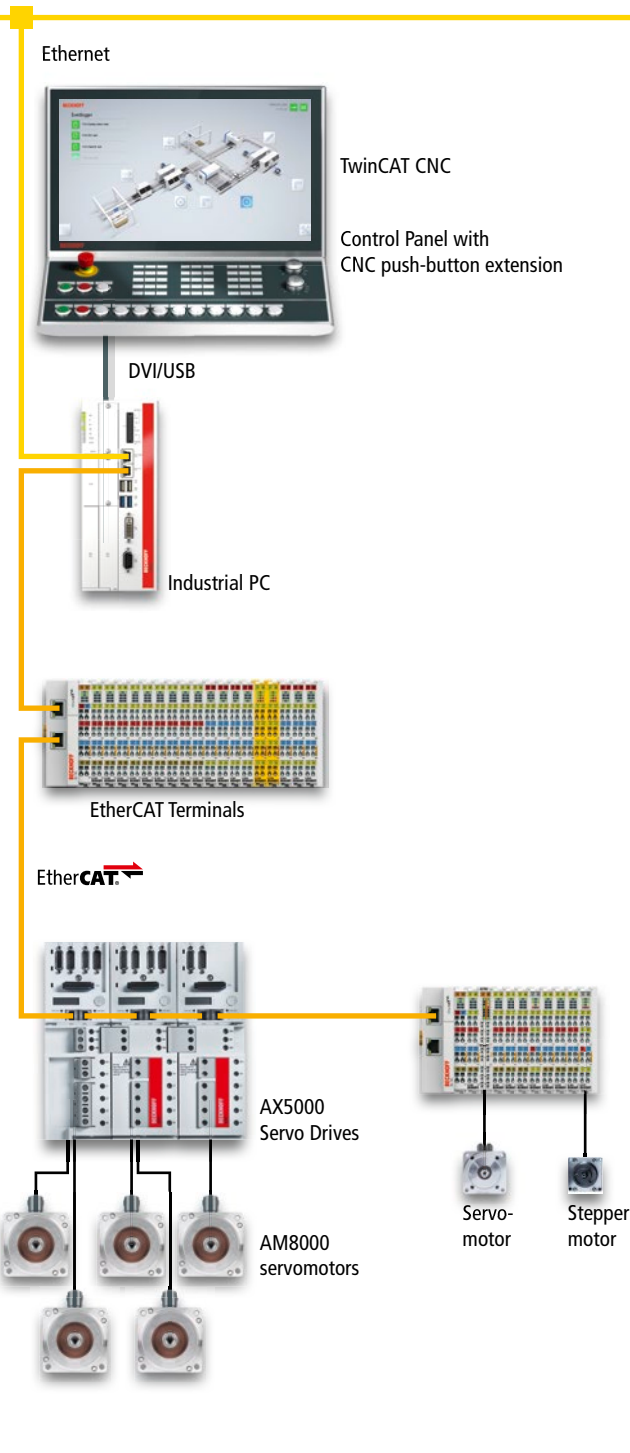

## Surface machining

The performance-related scalability of the control platform, as well as support for different fieldbus systems while using the same programming and project engineering tools provides a means for universal, economical, and flexible plant planning. The difficulties related to the integration of numerous third-party control units become a thing of the past.

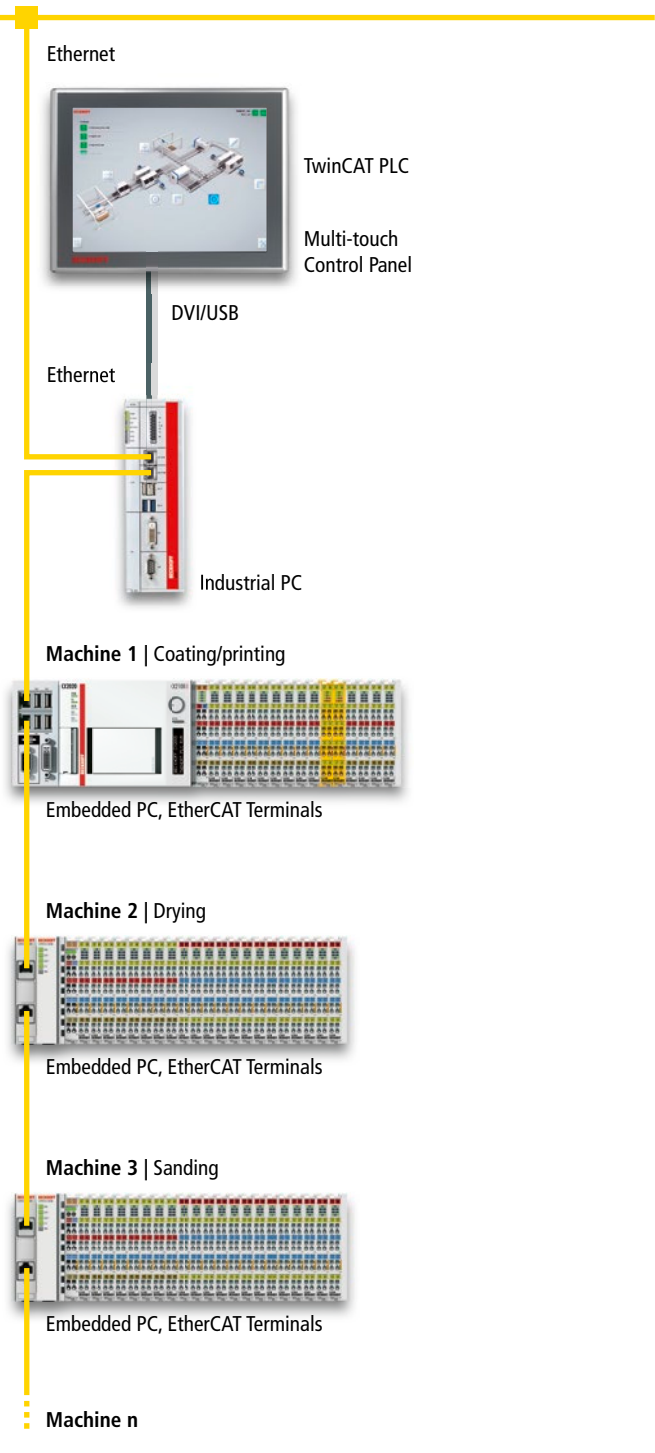

# Beckhoff – New Automation Technology

Beckhoff implements open automation systems based on PC Control technology. The product portfolio covers Industrial PCs, I/O and fieldbus components, drive technology and automation software. Products that can be used as separate components or integrated into a complete and seamless control system are available for all industries. The Beckhoff “New Automation Technology” philosophy represents universal and open control and automation solutions that are used worldwide in a wide variety of different applications, ranging from CNC-controlled machine tools to intelligent building automation.

► [www.beckhoff.com](http://www.beckhoff.com)

# Beckhoff at a glance

- Headquarters: Verl, Germany
- Sales 2016: 679 million € (+9.5 %)
- Staff worldwide: 3,350
- Branch Offices Germany: 19
- Subsidiaries/Branch Offices worldwide: 34
- Distributors worldwide: in more than 75 countries (as of 04/2017)

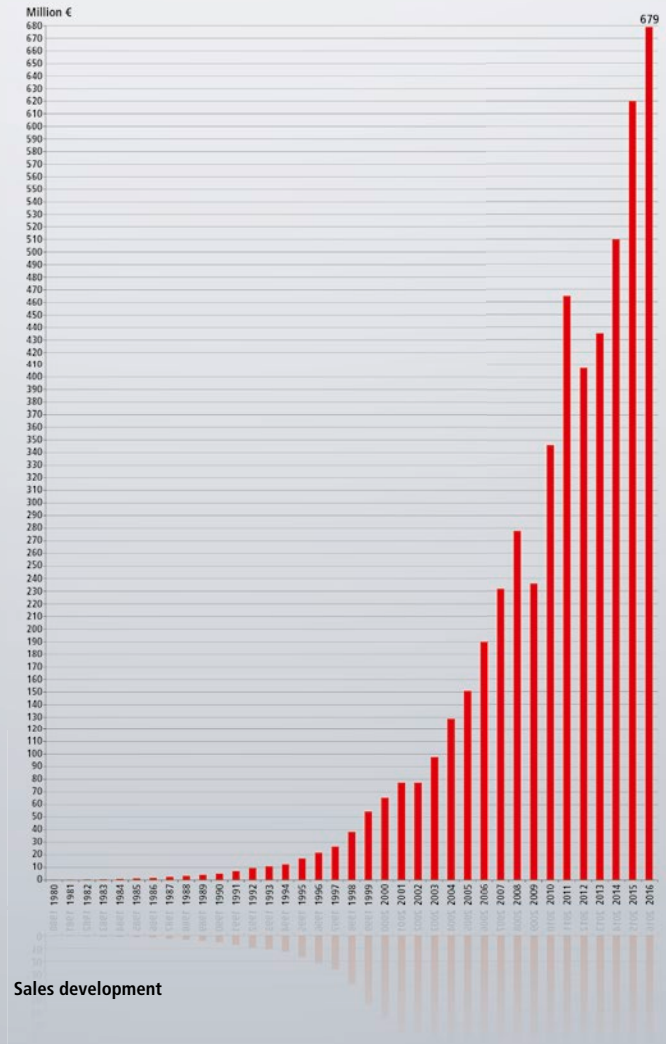

# Worldwide presence on all continents

With local presence in more than 75 countries, Beckhoff ensures fast service worldwide and technical support in the local language for globally operating customers. In addition, Beckhoff sees close geographic proximity to the customer as a prerequisite for a profound understanding of the technical challenges facing customers.

# Further information

The webpage "PC-based Control for Woodworking Machines" on the Beckhoff website provides additional information and industry solutions.

► [www.beckhoff.com/wood](http://www.beckhoff.com/wood)

The Beckhoff catalogs and flyers are available for download from our website.

► [www.beckhoff.com/media](http://www.beckhoff.com/media)

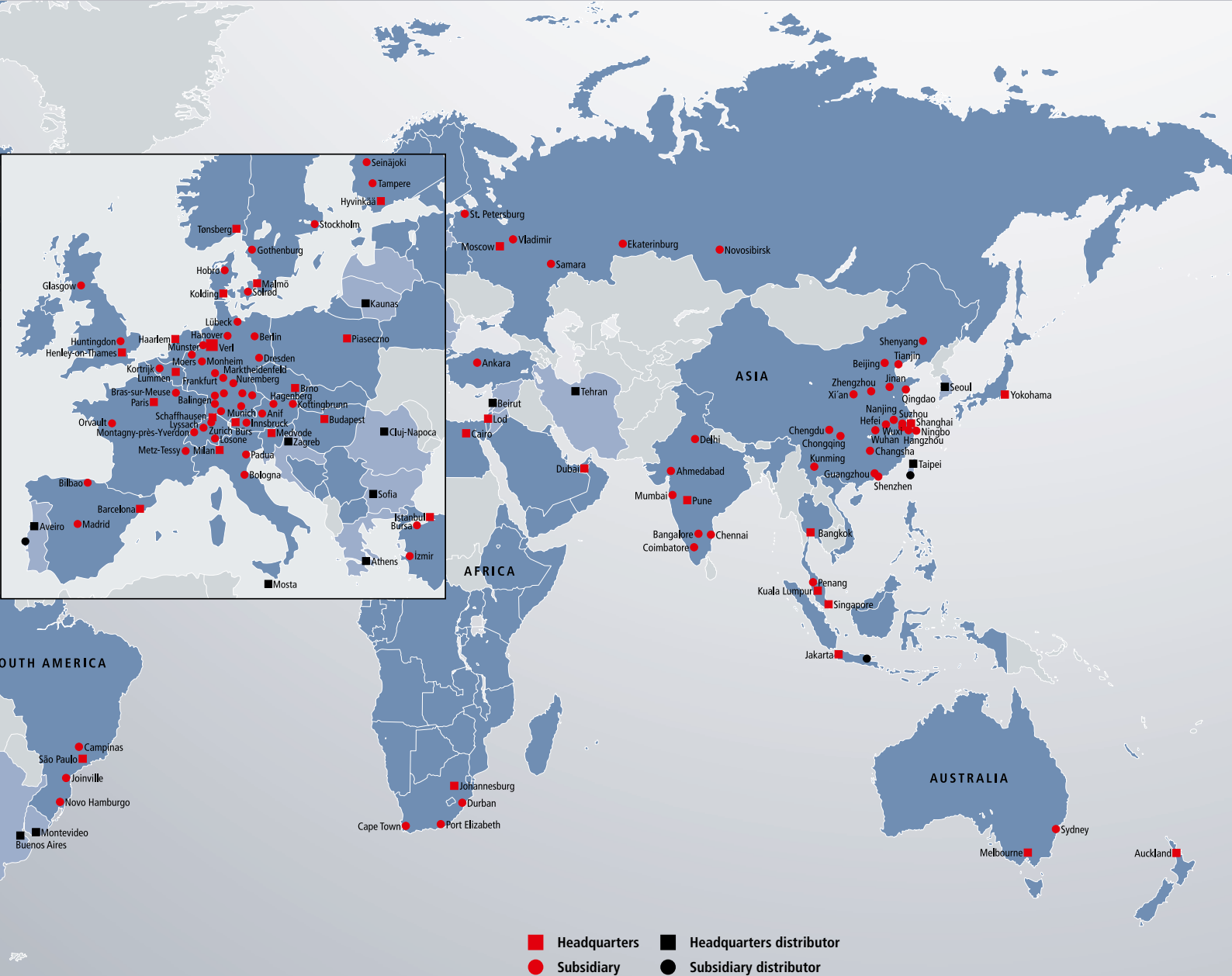

Contact us:

► [www.beckhoff.com/wood](http://www.beckhoff.com/wood)

**Beckhoff Automation GmbH & Co. KG**

Huelshorstweg 20

33415 Verl

Germany

Phone: + 49 5246 963-0

[info@beckhoff.com](mailto:info@beckhoff.com)

[www.beckhoff.com](http://www.beckhoff.com)

Beckhoff®, TwinCAT®, EtherCAT®, EtherCAT P®, Safety over EtherCAT®, TwinSAFE®, XFC® and XTS® are registered trademarks of and licensed by Beckhoff Automation GmbH. Other designations used in this publication may be trademarks whose use by third parties for their own purposes could violate the rights of the owners.

© Beckhoff Automation GmbH & Co. KG 05/2017

The information provided in this brochure contains merely general descriptions or characteristics of performance which in case of actual application do not always apply as described or which may change as a result of further development of the products. An obligation to provide the respective characteristics shall only exist if expressly agreed in the terms of contract.

Picture credits: BIESSE S.p.A., Italy | NOBILIA-Werke J. Sticking GmbH & Co. KG, Germany | Koch Technology GmbH & Co. KG, Germany | Kraft Maschinenbau GmbH, Germany